

Contents

About this manual

Overview

LED Indication

Audio Cues

Compatibility

Wire Up Your Charger

Tools You May Need

Wiring Steps

Auto Start-up via Ignition (Professional Installation Recommended)

Install Your Charger (Recommend)

Getting Started

Power On/Off

How to Unplug Cables

Smart Control

Bind Your Charger

Initial Inclusion

Working Modes

Using with In-Vehicle Infotainment System (CarPlay / Android Auto)

Maintenance

Cable Replacement

What's in the Box

Specifications

Safety Instructions



Please note that this manual may be updated without prior notice. If you are reading this manual in PDF format, please note that you can access it online at [EcoFlow Support](#) for a better experience and the latest updates.

About this manual

- This manual contains detailed information about product features, operation, management, and maintenance.
- In this manual, the EcoFlow Alternator Charger 600 will be referred to as "this product" or "alternator charger," and the car starting battery and RV house battery will be referred to collectively as "car battery."
- The illustrations in this manual are for reference only. Please refer to the actual product received.
- Some accessories and functions described in this manual may not be applicable to your country or region.
- For accessories compatible with the Alternator Charger, please refer to: [Cables Manual](#).

Overview

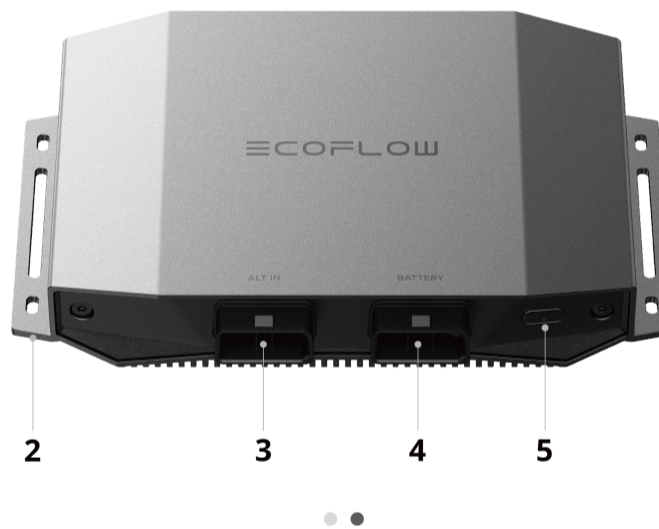

1	LED Indicators	Displays the product's operating status.
2	Mounting Holes	Used to securely mount the product.
3	ALT IN Port	Connects to the car battery via the input cable.
4	BATTERY Port	Connects to an EcoFlow portable power station via the output cable.
5	Main Power Control Button	Power On/Off: Press the button once to turn on the power station. Long press the button for 2 seconds to turn it off. Reset IoT: When powered off, press and hold for 5 seconds to reset Bluetooth and Wi-Fi connections.

LED Indication



State	Indication
Outward flowing light	Powering on.
Inward flowing light	Powering off.
Slowing blinking	Connecting to the Internet.

Three short blinks	Setting complete (e.g. successfully connected to internet or IoT reset finished.)
Two-way flowing light	Firmware is upgrading.
Continuous blinking	Malfunction detected.
One-way flowing light	<ul style="list-style-type: none"> · ALT IN Port → BATTERY Port: Charge mode (battery is being charged). · BATTERY Port → ALT IN Port: Reverse charge or battery maintenance mode.
Light On	Device connected to the corresponding port. <ul style="list-style-type: none"> · Left Light: BATTERY Port · Right Light: ALT Port
Light Off	Device disconnected from the corresponding port. <ul style="list-style-type: none"> · Left Light: BATTERY Port · Right Light: ALT Port

Audio Cues

Power-on Chime	The product is powering on.
Power-off Chime	The product is powering off.
Single Beep	Status Change or Confirmation , including: Mode switching, Charging initiated, Device connection (ALT, BATTERY), Successful Bluetooth pairing, and Fault alarm
Double Beep	Reset Successful

Compatibility

The Alternator Charger must be connected to both a car battery and a portable power station to enable power flow between them.



Are there any requirements for car models?

The overall voltage of some older or special car models is relatively low and the charger may fail to work as a result. In this case, use the EcoFlow app to adjust the start voltage of the charger.

Vehicle Starter Battery or RV House Battery

Please make sure the vehicle starter battery or RV house battery is **undamaged and rechargeable**. The battery's nominal voltage should be **12V or 24V**.

Portable Power Station or Extra Battery

The alternator charger is mainly compatible with EcoFlow portable power stations as well as other portable power products:

- Through an **XT150 Output Cable**, the product can connect to an EcoFlow portable power station or extra battery with an XT150 port.
- Through an **XT60 Output Cable**, the product can connect to portable power stations with an XT60 port, including both EcoFlow products and compatible third-party products.
- Through the **EcoFlow Alternator Charger 4+8 Output Cable for Quick Connection** (sold separately), the product can connect to **EcoFlow DELTA Pro series and its extra battery, DELTA 3 Max Plus, and DELTA 3 Ultra Plus**.



- If you have an EcoFlow Alternator Charger Plus 1000, you will need to purchase a separate XT60 Output Cable to connect it to an EcoFlow portable power station or third-party product equipped with an XT60 port.
- If you have an EcoFlow Alternator Charger 600, you will need to purchase a separate XT150 output cable to connect it to an EcoFlow portable power station equipped with XT150 port(s).

Wire Up Your Charger



- It's recommended that the wiring is performed by a professional.
- Wear personal protective equipment (including protective goggles and gloves) during wiring and installation.
- When wiring, avoid high temperature, sharp, and friction-prone areas, and securely fasten the cables to avoid cable wear or loose connections caused by cable movement.
- Always adhere to the battery's safety instructions during installation.
- It's recommended to complete wiring before starting the vehicle and turning on the charger.
- Power off the charger and disconnect it before changing the wiring each time.

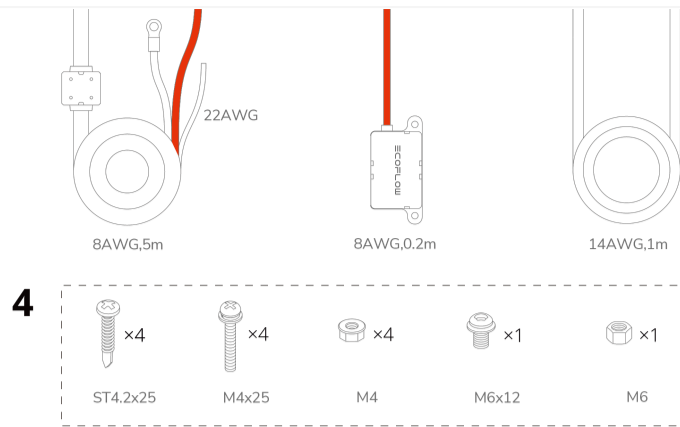

1	Alternator Input Cable Integrated with Ignition Cable (8WAG, 5m/16.4ft)	<Input Cable>: 5m (16.4ft), 6AWG wire gauge Connects to the vehicle's battery (positive and negaive terminals) and the charger's ALT IN Port.
2	125A Fuse Cable (8AWG, 0.2m/0.66ft)	<Fuse Cable>: 0.2m (0.66ft), 6AWG wire gauge Connects to the positive (+) battery terminal and the positive (+) terminal of the Input cable.
3	XT60 Output Cable (14AWG, 1m/3.28ft)	Connects the charger's BATTERY port to the XT60 port on a compatible Portable Power Station.
4	Mounting Fasteners	<p>Fasteners for secure installation</p> <p>A (x4): Self-taping screws ST4.225 B (x4): Bolts M425 C (x4): Nuts M4</p> <p>Fasteners for grounding</p> <p>D(x1) : M6 Bolt E(x1) : M6 Nut</p>

Tools You May Need

Protective Gear	Gloves: protect hands during wiring and installation
Electrical Tools	Multimeter: check the voltage and locate the correct fuse Electrical tape: insulate wire connections
Surface Preparation	Sandpaper: remove paint or rust from the grounding point
Fastening and Cable Management	Zip ties: secure cables in the engine compartment Trim removal tools: remove panels safely
Assembly Tools	Wrench: tighten bolts and nuts Screwdriver / Power screwdriver: tighten screws Impact drill: secure heavy-duty fasteners
Light	Flashlight: illuminate dark or tight spaces of the car

Wiring Steps

- ⚠ For safety and optimal performance, we recommend having wiring completed by a qualified professional.
- The illustrations and instructions in this section demonstrate connecting the product to a vehicle starting battery in a typical SUV.
- If your vehicle configuration is different, or if you are connecting the product to an RV house battery, adjust the wiring according to your specific vehicle and needs.
- The wiring process involves connecting several cables to various points. To ensure accurate installation, please take your time to carefully review each step and refer to the accompanying illustrations.

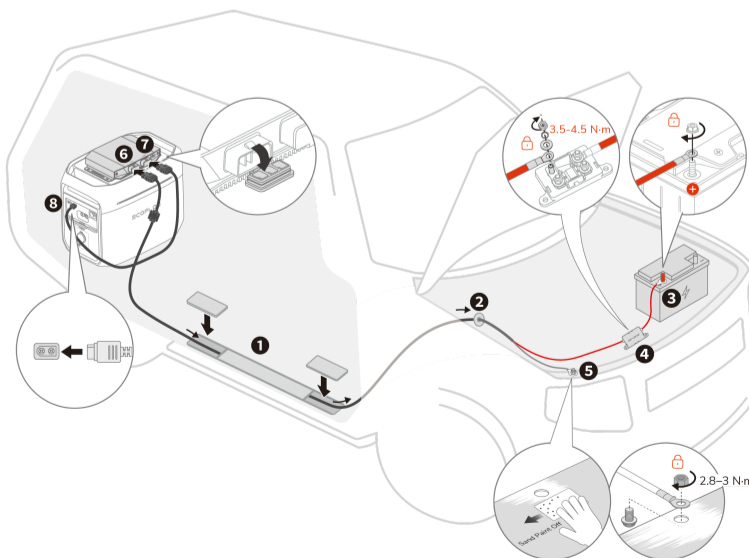

①② Routing the Input Cable

you're unsure of its location.

2. Locate a suitable opening in the firewall (the barrier between the passenger compartment and the engine compartment) through which to route the cable. Existing wiring grommets or unused access points are ideal. If you need to create a new opening, consult a professional.

3. Carefully route the end of the input cable with the OT terminal from the rear of the vehicle, through the identified opening in the firewall, and into the engine compartment. Ensure the cable is routed away from any moving parts, sharp edges, or heat sources.

③④ Connecting the 125A Fuse Cable

1. Connect the OT terminal of the fuse cable to the positive (+) terminal of the vehicle battery.

2. Open the fuse cable box and remove the nut and washers from the unwired side. Place the input cable's positive (+) OT terminal onto the stud, followed by the large washer, small washer, and the nut. Tighten the nut to a torque of 3.5-4.5 N*m.

Caution: Apply the specified torque when tightening the nut. Insufficient torque can result in a loose connection and melted wires, or damage to the fuse.

⑤ Grounding the Input Cable

1. Identify a clean, unpainted metal surface on the vehicle chassis (frame) within the engine compartment. If the surface is painted or has rust/corrosion, use sandpaper to thoroughly remove it, ensuring a bare metal surface for a good electrical connection.

2. Using the supplied M6 bolt and nut, connect the OT terminal of the input cable's negative (-) wire to the prepared grounding point on the vehicle chassis.

3. Using a wrench, tighten the nut to a torque of 2.8-3 N*m.

Important Notes:

- When connecting to a vehicle starting battery, do NOT connect the input cable's negative (-) wire to the starting battery's negative (-) terminal. Doing so may prevent the product from functioning properly.

- When connecting to an RV house battery, the input cable's negative (-) wire CAN be connected to the RV house battery's negative (-) terminal.

⑤* Securing the Cables

Use zip ties to secure the Input Cable and Fuse Cable to existing wiring harnesses or other stable components within the engine compartment. This will prevent the cables from moving freely and potentially melting due to engine heat.

⑥ Connecting Input Cable to the Alternator Charger

Connect the ALT IN end of the input cable to the ALT IN port on the Alternator Charger.

⑦⑧ Connecting XT150 Output Cable to the Alternator Charger

Connect the BATTERY end of the output cable to the BATTERY port on the Alternator Charger. Connect the other end to the XT150 connector on an EcoFlow portable power station.



1. Make sure that the Input Cable, Fuse Cable, and Output Cable are connected firmly as loose connections can cause cable melting.
2. To minimize the risk of fire, carefully route the input cable to avoid contact with any metal parts of the vehicle, particularly the seat frame. Regularly inspect the cable for signs of abrasion or damage. Damaged cables can create a short circuit and pose a fire hazard.

Auto Start-up via Ignition (Professional Installation Recommended)

For added convenience, this Alternator Charger can be configured to automatically power on when the vehicle's ignition is engaged. This is achieved by connecting the built-in ignition wire (on the Input Cable) to the vehicle's ACC/IGN fuse box. Once the engine starts and the alternator is running, the Alternator Charger will receive a signal and power on automatically.

- ⓘ **Important:** Due to the complexity of automotive electrical systems and the potential risks involved, installation should be carried out by a qualified automotive electrician. Incorrect fuse selection or improper wiring of the ignition wire may result in damage to the vehicle's electrical system or the product itself. If you choose to attempt setup yourself, carefully follow the vehicle manufacturer's documentation or search online for fuse diagram of your specific vehicle model to locate the ACC/IGN fuse box.

Locate the ACC/IGN Fuse Box

Common fuse box locations include:

- Inside the engine compartment
- Beneath the dashboard
- Under the driver's seat

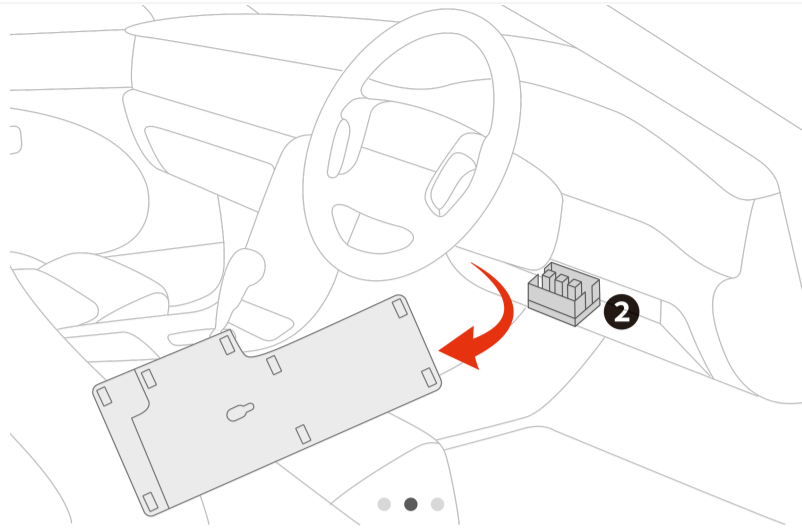

Identifying the Correct ACC/IGN Fuse

To locate the correct fuse:

1. Use a multimeter to test the fuses.
2. The correct fuse should have no power when the ignition is off, and have power when the ignition is on.

Making the Connection

Once the correct fuse has been identified:

1. Strip the end of the ignition wire.
2. Wrap the exposed copper core around the fuse terminal.
3. Secure the connection using electrical insulation tape.

WARNING:

- Always ensure secure insulation to avoid short circuits.
- Any damage resulting from self-installation is not covered under warranty.

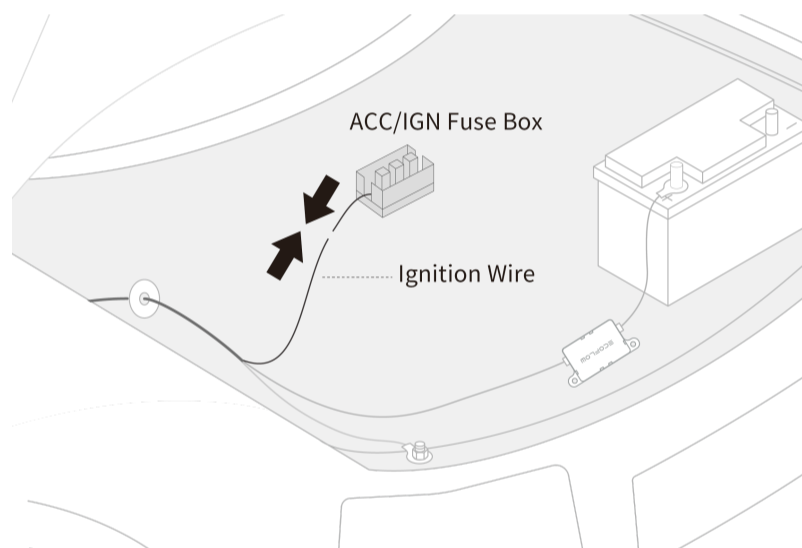

Install Your Charger (Recommend)

To make sure the charger can operate normally, the location where the charger is placed or installed should meet the following requirements:

1. Stay close to the portable power station or extra battery, as the output cable is only 1 meter long and cannot be extended without modification. (For your reference, the wire gauge of each cable is indicated in its name.)
2. Has adequate connection space around the ports.
3. Be dry and tidy with a moderate temperature and away from heat sources.
4. Be away from flammable substances as the charger produces heat when it's in use.
5. Be well-ventilated and not covered by blankets or anything that will hinder ventilation.
6. Be away from children and pets.



For smooth rides, you can place the charger on the power station. But we recommend to install the charger securely.

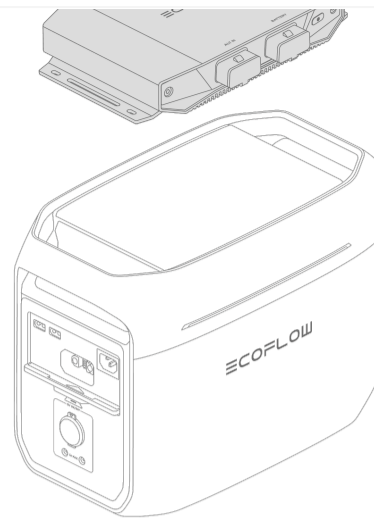

⚠ Do not flush mount the product to ensure proper ventilation.

Method 1

You can use the included self-tapping screws (marked with "A" on the item list) to install the charger on the body or frame of your vehicle.

Suitable for: Mounting surfaces made of soft materials.

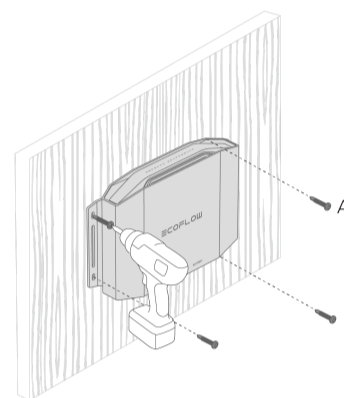

Steps

1. Use a power screwdriver, insert the four self-tapping screws (included) through the product's mounting holes and into the mounting surface.
2. Tighten the screws to a torque of 0.8-1 N·m.

Method 2

Suitable for: Mounting surfaces made of hard materials.

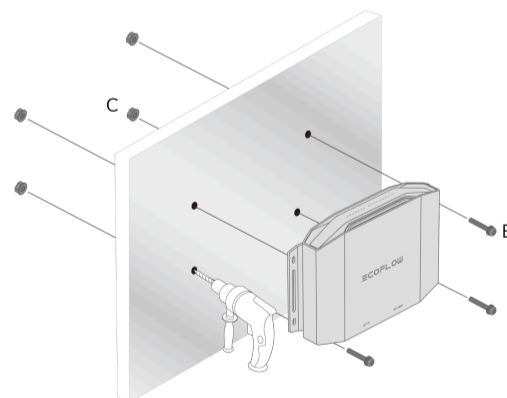

Steps

1. Position the product to mark the drilling locations and use a marker to indicate the positions.
2. Drill four holes with a diameter of 4.5 mm (approximately 3/16 inch) at the marked locations.
3. Insert M4 bolts (B) through the mounting holes, then tighten the M4 nuts (C).

⚠ To allow sufficient space for cable routing, it is recommended that the distance between the bottom mounting holes and the lower edge of the mounting surface be at least 18 cm (7 inches).

Getting Started

Power On/Off

- **Power On:** Short press the alternator charger control button.
- **Power Off:** Long press the control button for 2s.

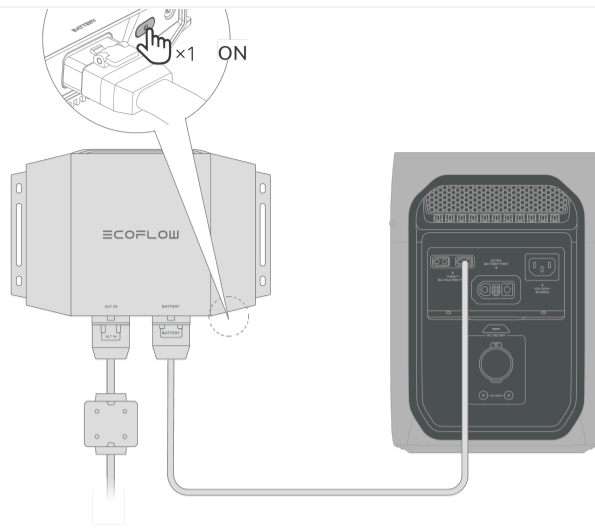

To ensure that the charger will operate normally, please complete the wiring as instructed first, and then power on the power station or extra battery before you start your vehicle.

- 1 To make sure the charger will operate normally, please upgrade your portable power station or extra battery's firmware to the latest version before use.

How to Unplug Cables

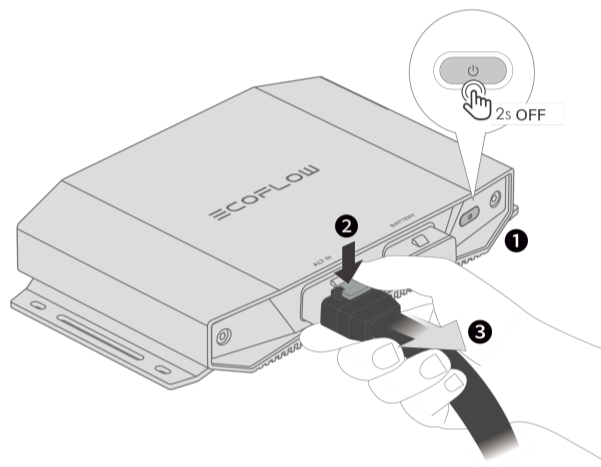

To unplug the cable from the Alternator Charger, follow these steps:

1. Press and hold the control button for 2 seconds to turn off the Alternator Charger.
2. Press the button on the cable connector and pull the cable out.

Smart Control

Bind Your Charger

The Alternator Charger requires connection to the EcoFlow app to enable operation and select working modes.



The EcoFlow app is continuously updated and improved to enhance user experience and add new features. The screenshots in this manual are for illustrative purposes only; the actual app interface may vary depending on your app version and operating system. This manual does not cover all app functions, so we encourage you to explore the app to discover more ways to use it.

Download the EcoFlow App

You can download the EcoFlow app in the following ways:

1. Scan the QR code.
2. Search for "EcoFlow" in the iOS App Store or Google Play Store.
3. Visit <https://download.ecoflow.com/app>



<https://download.ecoflow.com/app>



Bind Steps

1. Visit the EcoFlow app and log into your EcoFlow account. If you don't have an account, create one first.
2. Tap the "Add Device" button or the "+" icon in the top right corner to search for new EcoFlow devices.
3. Turn on Bluetooth on your phone and bind the device to your EcoFlow account.
4. Connect to the Internet (optional).

After connecting the charger to the Internet, you can manage the charger from afar. If Internet connection is not available, you can manage the charger via Bluetooth.

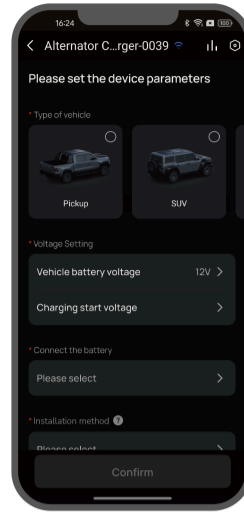

Before using the Alternator Charger for the first time, complete the initial setup in the EcoFlow app. The app will guide you through selecting your **vehicle type**, **battery voltage**, **starting voltage**, **portable power station model**, and **installation methods**.

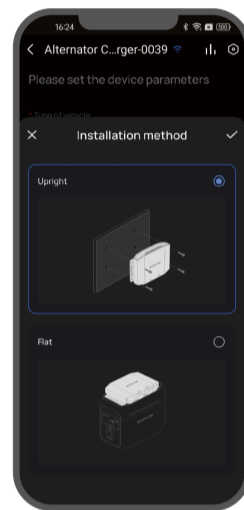

 To ensure proper operation, the installation method you select in the app must correspond to the way you actually installed the Alternator Charger in your vehicle.

Working Modes

When connected using the provided XT60 output cable, only Charge Mode is available.

However, by purchasing the EcoFlow Alternator Charger XT150 Output Cable for Quick Connection and pairing it with a portable power station equipped with an XT150 port, you can utilize three operating modes:

- Charge Mode
- Reverse Charge Mode
- and Battery Maintenance Mode.

Charge Mode

- **Power Flow:** Alternator → Vehicle Starter Battery or RV House Battery or Solar Panel(s) → Alternator Charger → Portable Power Station or Extra Battery
- **Maximum Power:** 600W

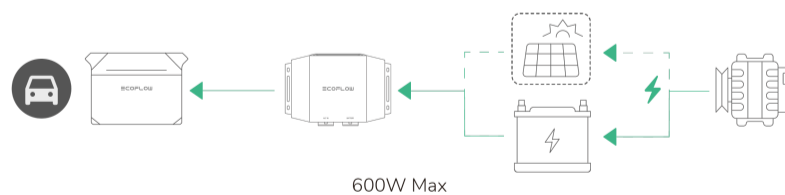

With the portable power station or extra battery powered on, when your vehicle is in motion, the charger can use the alternator's redundant power to charge the portable power station or extra battery.

In Charge Mode, the actual output power is influenced by the motion state and the model of the vehicle.

When using the XT60 output cable to connect the Alternator Charger, the charging speed may be limited by both the input capacity of the portable power station and the XT60 cable itself. For example, when connected to DELTA 3 via the XT60 output cable, the Alternator Charger's maximum charging power is limited to 500W.

To prevent the vehicle starter battery or RV house battery from overdischarging, in Charge Mode, the charger will measure the voltage of the battery. If the measured value is lower than the charger's start voltage, the charger will stop working.

 For your driving safety, in Charge Mode, if the vehicle is in motion, it is recommended not to change the operating mode.

Battery Maintenance Mode

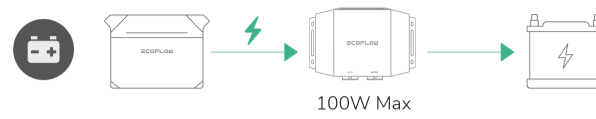

After powering on the portable power station or extra battery, you can use the charger to keep your starter battery charged at an optimal level over an extended period of time. It helps extend the lifespan of the battery and ensures that it is ready for use when needed.

Reverse Charge Mode

- **Power Flow:** Portable Power Station or Extra Battery or Solar Panel(s) → Alternator Charger → Vehicle Starter Battery or RV House Battery
- **Maximum Power:** 600W

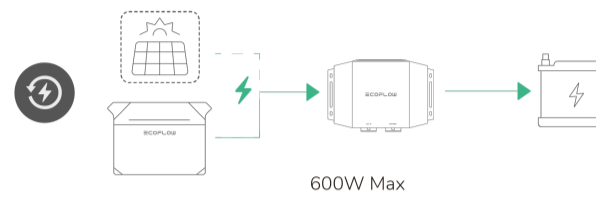

With the portable power station or extra battery powered on, the charger will charge the vehicle starter battery or RV house battery.

How to Switch Modes

You need to go to the device detail page on the app and tap on a mode icon and use the slider control to switch mode and start charging.

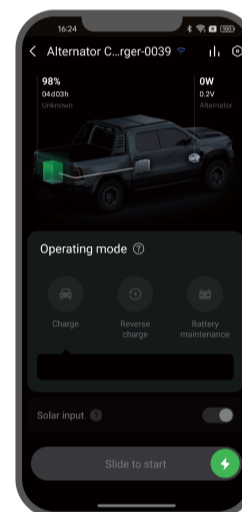

How to Start or Stop Charging

To start or stop the product's operation, use the slider control located at the bottom of the device's home screen in the EcoFlow app.

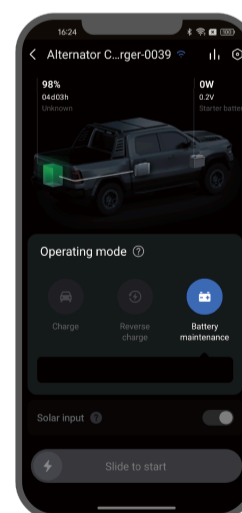

Using with In-Vehicle Infotainment System (CarPlay / Android Auto)

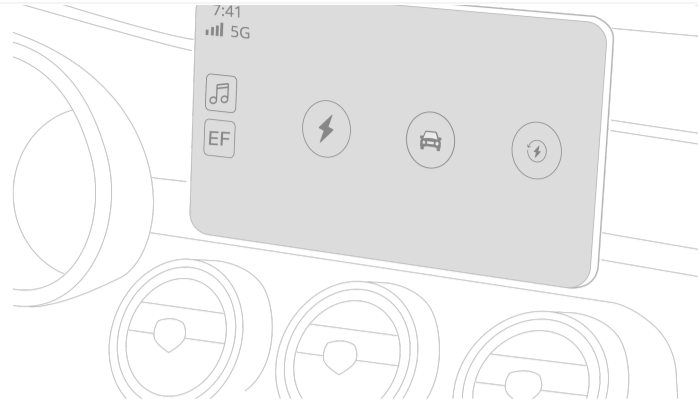

1. To use in-vehicle control, first bind the device to the EcoFlow App (version 6.7.0 or later).
2. Then, connect your phone to the vehicle's infotainment system. When the EF logo appears on the car display, tap it to view and control the device directly from the vehicle screen.

Maintenance

1. Inspect the cables every month and ensure that the terminals are tight. Look out for cracks, abrasions, and corrosion on the cables. If you notice any of this, stop using the cables immediately and follow the instructions in the "Cable Replacement" section.
2. Use dry, soft, and clean cloth or paper towels to clean the charger.

 For continued protection against risk of fire, or electric shock, replace only with same type and ratings of fuse.

Cable Replacement

1. To replace the Output Cable, purchase new cables from EcoFlow's official sales channels.
2. To replace the Input Cable, Fuse Cable, or Fuse, consult EcoFlow's official customer service for purchase suggestions and ask a professional for replacement.

Input Cable	Fuse Cable	Fuse
Size: 8 AWG Size of Ignition Wire: 22AWG	Size: 8 AWG	Rated Current: 125A

What's in the Box

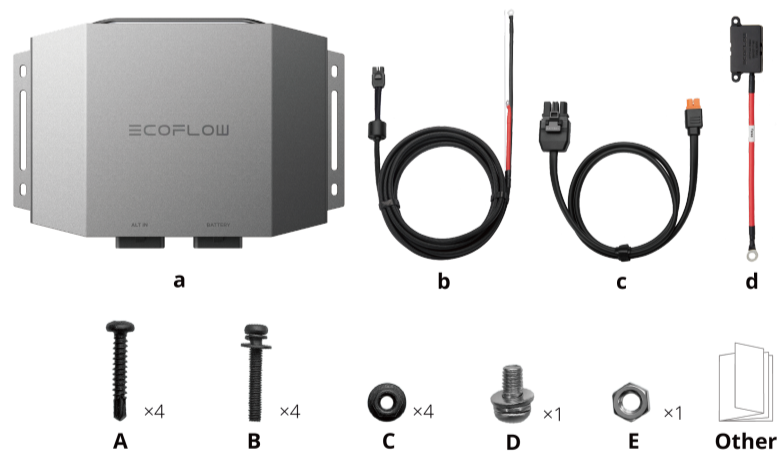

a. EcoFlow Alternator Charger 600

Cables

- Alternator Input Cable Integrated with Ignition Cable (8WAG, 5m/16.4ft)
- XT60 Output Cable (14AWG, 1m/3.28ft)
- 125A Fuse Cable (8AWG, 0.2m/0.66ft)

Mounting Fasteners

- A (x4): Self-taping screws ST4.2x25
 B (x4): Bolts M4x25
 C (x4): Nuts M4
 D (x1) : M6 Bolt
 E (x1) : M6 Nut

Others

Quick Start Guide & Safety Instructions & Warranty Card

Specifications

Net Weight	Approximately 1.1 kg
Dimensions (W × D × H)	224×153×38 mm
Wi-Fi	Supported
Bluetooth	Supported
Charge Mode	ALT IN Port Input: 12/24V $\overline{=}$ (11-31V $\overline{=}$), 45A Max BATTERY Port Output: 24V $\overline{=}$ /40-60V $\overline{=}$, 12A Max, 600W Max
Battery Maintenance Mode	BATTERY Port Input: 40-60V $\overline{=}$, 3A Max ALT IN Port Output: 13.8/27.6V $\overline{=}$, 100W Max
Reverse Charge Mode	BATTERY Port Input: 40-60V $\overline{=}$, 12A Max ALT IN Port Output: 13.8/27.6V $\overline{=}$, 45A Max
Rated Current of Fuse	125A
Protection Type	Reverse polarity protection/Overcurrent protection/Short circuit protection/Overvoltage and undervoltage protection (Provided with integral protection against overloads)
Operating Temperature	-10°C to 45°C (14°F to 113°F)
Storage Temperature	-30°C to 70°C (-22°F to 158°F)
Operating Humidity	≤95%
Storage Humidity	≤95%

Safety Instructions

Wiring and Installation

1. It's recommended that the wiring is performed by a professional.
2. The installation method must be consistent with the installation method selected in the app.
3. Wear personal protective equipment (including protective goggles and gloves) during wiring and installation.
4. It's recommended to complete wiring before starting the vehicle and turning on the charger.
5. Apply the specified torque when connecting the fuse cable to the positive terminal of the input cable. Improper torque may result in a loose connection, cable melting, or fuse damage.
6. Make sure that the cables are firmly connected, as loose connections can cause cables to melt.
7. Avoid reversing the polarity of the positive and negative connections when connecting to the vehicle starter battery or RV house battery.
8. When connecting to the chassis, be sure to remove any paint or rust at the grounding point to ensure a reliable connection.
9. When wiring, avoid high temperature, sharp, and friction-prone areas, and securely fasten the cables to avoid cable wear or loose connections caused by cable movement.
10. Refer to the specifications of the vehicle starter battery or RV house battery and make sure that its nominal voltage is 12V or 24V. Always observe the safety instructions of the battery during use.
11. Do not use the charger with damaged or non-rechargeable batteries.
12. Power off the charger and disconnect it before changing the wiring each time.
13. Tighten screws or bolts to the specified torque during installation.
14. CAUTION: To reduce the risk of fire, use only battery packs that include the battery management system and all necessary protection for the battery pack integral to the pack.

Cable Replacement

1. To replace the output cable, purchase new cables from EcoFlow's official sales channels.
2. To replace the input cable, fuse cable, or fuse, consult EcoFlow's official customer service for purchase suggestions and ask a professional for replacement.
3. CAUTION: For continued protection against risk of fire, or electric shock, replace only with same type and ratings of fuse.

Input Cable: Size 8AWG, Size of Ignition Wire 22AWG

Fuse Cable: Size 8AWG

Fuse Rated Current: 125A

Environmental Requirements

1. Install and use the charger in a dry and tidy environment with a moderate temperature.
2. Keep the charger away from heat sources and wet environments.
3. Keep the charger away from flammable substances as the charger produces heat when it's in use.
4. Use the product in an area with good ventilation and pay attention not to cover the product with blankets or anything that will hinder ventilation.
5. Do not wet the charger, or soak it in water or any other liquids.
6. Keep children and pets away from the charger.
7. Do not flush mount the product to ensure proper ventilation.

Daily Use

1. Power off the charger before plugging or unplugging cables.
2. Inspect the cables every month and ensure that the terminals are tight. Look out for cracks, abrasions, and corrosion on the cables. If you notice any of this, stop using the cables immediately and follow the instructions in the "Cable Replacement" section.
3. Avoid prolonged contact with the charger when it is in use.
4. Use dry, soft, and clean cloth or paper towels to clean the charger.

In Case of Emergency

1. In case of emergency, take precautions against electric shock (wear insulating gloves, for instance) before touching the charger.
2. If the charger gets wet, stop using it immediately and refrain from further operation or powering it on. Place the charger in a secure, waterproof, and well-ventilated area, then contact EcoFlow's official customer service for assistance.
3. If the charger falls into water, place it in a secure, waterproof, and well-ventilated area, and keep it away from contact until it is completely dry. The dried charger should not be used again and must be properly disposed of according to local laws and regulations.
4. If the charger catches fire, we recommend that you use the fire extinguishers in the following order: water or water mist, sand, fire blanket, dry powder, and finally a carbon dioxide fire extinguisher.
5. If the charger is overturned and severely damaged, wear insulating gloves to turn it off, and then place the charger in an open area far from flammable materials and people, and dispose of it according to local laws and regulations.

Copyright © 2026 EcoFlow. All Rights Reserved.